



# Groundwater Monitoring Solutions

# Diver



# Groundwater Management System

### Beijing Water International

Beijing Water International Ltd.(BWI) is affiliated with S.S. Papadopoulos & Associates, Inc. (SSP&A) and specializing in groundwater software development and groundwater consulting in China. SSP&A is a leader in environmental and water resource consulting in the United States (<http://www.sspa.com>). Since its beginnings in 1979, SSPA has been at the forefront of the water resource and groundwater industry, successfully completing hundreds of projects in water resource development and management, environmental impact assessment, groundwater contamination and remediation throughout the United States and internationally. By combining the expertise of a leading international firm and Chinese groundwater experts, BWI strives to provide the best groundwater modeling software and outstanding professional consulting services to clients in industry and government.

### Groundwater monitoring - Diver

Water depletion, excess water (flooding), salinization and shortage of clean drinking water. Today these problems occur with growing frequency world-wide. Regular and reliable measuring and monitoring of groundwater levels has therefore become more important than before. The Diver, by Van Essen Instruments – part of Schlumberger Water Services (SWS) – is the ideal instrument for this purpose.

The Diver is a robust and compact datalogger for the automatic, accurate and reliable monitoring of groundwater levels. The Diver is available in a range of different models that can measure temperature and groundwater level. Depending on the model, the water conductivity can also be measured.

### Suitable for any environment

Divers incorporate the full experience built up by SWS in groundwater systems over many decades. These high-quality dataloggers are hermetically sealed to external effects, so moisture and/or electrical influences cannot affect the measurement result. The following four Diver models are available to suit various environments and areas of application.

- Mini-Diver
- Micro-Diver
- Cera-Diver
- CTD-Diver

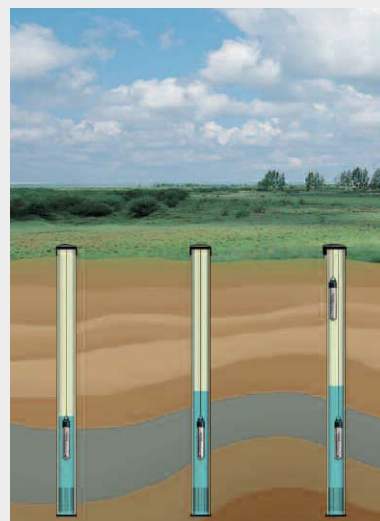

### Accuracy of measurement

The Diver monitors the groundwater level by measuring the pressure of the water column with a pressure sensor to an accuracy up to 0.05% FS (Full Scale). In addition to a pressure sensor and a temperature sensor, the CTD-Diver is equipped with a four-electrode sensor for determining the conductivity. In order to determine the groundwater level, the prevailing air pressure must be compensated by means of the BaroDiver. The Compensation Wizard in Logger Data Manager (LDM) compensates the barometric measurement data from the BaroDiver. The result: continuous and highly reliable measurements.

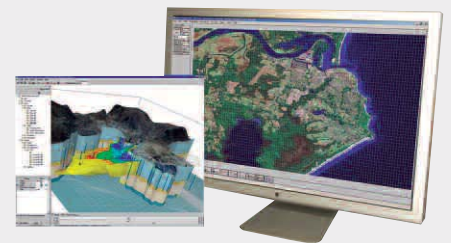

### Installation, programming and readout

Diver dataloggers are simply suspended in a monitoring well from a steel wire or Diver Data Cable (DDC). Once installed the monitoring system is completely invisible above ground, reducing the risk of vandalism.

For programming of the Diver and for compensation and readout of measured data, SWS offers LDM software package for laptop or PC applications, and the Pocket-Diver package for PocketPC.

# Mini-Diver datalogger



## Applications:

- Monitoring projects
- Groundwater monitoring network automation

## Mini-Diver: the proven concept

The Mini-Diver is based on an ingenious and proven concept and is acknowledged as the most reliable instrument for the autonomous measuring and recording of groundwater level and temperature. Its internal memory of 24,000 measurements per parameter provides sufficient capacity to perform nearly one measurement every ten minutes for six months. For each measurement, the Diver registers the date and time, groundwater level and temperature. The built-in battery has an expected lifespan of 10 years. Its compact dimensions (Ø22 mm, length 90 mm) mean that the Mini-Diver will fit into virtually any monitoring well.



## Highlights:

- 3 year warranty
- Long-term and frequent measurements
- Temperature corrected measurement
- Reliable and accurate measurement data
- Non-volatile memory
- Compact size
- Hermetically sealed in stainless steel housing
- Free of maintenance

## Specifications:

Dimensions	Ø22 mm x 90 mm
Memory	24,000 measurements (non-volatile)
Sample rate	0.5 sec to 99 hours
Housing material	RVS 316L
Pressure sensor material	ceramic (Al <sub>2</sub> O <sub>3</sub> )
Temperature range	-20 °C to 80 °C
- accuracy	±0.1 °C
- resolution	0.01 °C
- compensated range	0 °C to 40 °C
Battery life	10 years (depending on use)
Weight	70 grams



## Mini-Diver® Technical specifications (pressure)

Type	DI 501	DI 502	DI 505	DI 510	DI 500 (Baro)
Range	10 m H <sub>2</sub> O	20 m H <sub>2</sub> O	50 m H <sub>2</sub> O	100 m H <sub>2</sub> O	1.5 m H <sub>2</sub> O
- accuracy**	0.5 cm H <sub>2</sub> O	1 cm H <sub>2</sub> O	2.5 cm H <sub>2</sub> O	5 cm H <sub>2</sub> O	0.5 m H <sub>2</sub> O
- resolution	0.2 cm H <sub>2</sub> O	0.4 cm H <sub>2</sub> O	1 cm H <sub>2</sub> O	2 cm H <sub>2</sub> O	0.1 cm H <sub>2</sub> O

\*\* within temperature compensated range



# Micro-Diver datalogger



## Applications:

- Monitoring projects
- Groundwater monitoring network automation
- Pumping tests

## Micro-Diver: small in size, great in performance

With its length of 90 mm and diameter of only 18 mm, the Micro-Diver is the smallest Diver that is capable of recording groundwater levels and groundwater temperatures with extreme accuracy. The Micro-Diver is specifically designed for monitoring wells too small to accommodate larger data loggers. In spite of its small size, the Micro-Diver possesses a memory capacity of 48,000 measurements per parameter, sufficient to enable it to perform almost one measurement every ten minutes for a whole year. The built-in battery has a lifespan of about 10 years. With its range of measuring functions, the Micro-Diver can be used both for fixed, event-dependent and averaging as well as pump test measurements.



## Highlights:

- 3 year warranty
- Long-term and frequent measurements
- Various measurement methods:
  - fixed
  - event dependent
  - averaging
  - pumping tests
- Temperature corrected measurement
- Reliable and accurate measurement data
- Large memory capacity (non-volatile)
- Compact size
- Suitable for 19 mm monitoring wells
- Hermetically sealed in stainless steel housing
- Free of maintenance

## Specifications:

Dimensions	Ø18 mm x 90 mm
Memory	48,000 measurements (non-volatile)
Sample rate *	0.5 sec to 99 hours
Housing material	RVS 316L
Pressure sensor material	ceramic (Al <sub>2</sub> O <sub>3</sub> )
Temperature range	-20 °C to 80 °C
- accuracy	±0.1 °C
- resolution	0.01 °C
- compensated range	0 °C to 40 °C
Battery life	10 years (depending on use)
Weight	60 grams



## Micro-Diver® Technical specifications (pressure)

Type	DI 601	DI 602	DI 605	DI 610	DI 500 (Baro)
Range	10 m H <sub>2</sub> O	20 m H <sub>2</sub> O	50 m H <sub>2</sub> O	100 m H <sub>2</sub> O	1.5 m H <sub>2</sub> O
- accuracy**	1 cm H <sub>2</sub> O	2 cm H <sub>2</sub> O	5 cm H <sub>2</sub> O	10 cm H <sub>2</sub> O	0.5 m H <sub>2</sub> O
- resolution	0.2 cm H <sub>2</sub> O	0.4 cm H <sub>2</sub> O	1 cm H <sub>2</sub> O	2 cm H <sub>2</sub> O	0.1 cm H <sub>2</sub> O

\* various measuring methods available (fixed, event based, averaging and pumping tests)

\*\* within temperature compensated range

# Cera-Diver datalogger



## Applications:

- Monitoring projects
- Groundwater monitoring network automation
- Pumping tests

## Cera-Diver: at home in any environment

To monitor groundwater under potentially corrosive conditions, as brackish water and seawater, requires a robust and durable datalogger. The ceramic Cera-Diver is designed specifically for such environments. Therefore the Cera-Diver can be perfectly used in projects together with the CTD-Diver. This highly reliable and compact Diver measures groundwater levels with an accuracy of 0.05% (FS). The Cera-Diver is equipped with a memory for 48,000 measurements per parameter, sufficient to enable it to perform nearly one measurement every ten minutes for a whole year. The built-in battery has a lifespan of approximately 10 years.



## Highlights:

- 3 year warranty
- Long-term and frequent measurements
- Various measurement methods:
  - fixed
  - event dependent
  - averaging
  - pumping tests
- Temperature corrected measurement
- Reliable and accurate measurement data
- Large memory capacity (non-volatile)
- Compact size
- Robust construction:
  - ceramic
  - corrosion resistant
- Free of maintenance

## Specifications:

Dimensions	Ø22 mm x 90 mm
Memory	48,000 measurements (non-volatile)
Sample rate *	0.5 sec to 99 hours
Housing material	ceramic (ZrO <sub>2</sub> )
Pressure sensor material	ceramic (Al <sub>2</sub> O <sub>3</sub> )
Temperature range	-20 °C to 80 °C
- accuracy	±0.1 °C
- resolution	0.01 °C
- compensated range	0 °C tot 40 °C
Battery life	10 years (depending on use)
Weight	55 grams



## Cera-Diver® Technical specifications (pressure)

Type	DI 701	DI 702	DI 705	DI 710	DI 500 (Baro)
Range	10 m H <sub>2</sub> O	20 m H <sub>2</sub> O	50 m H <sub>2</sub> O	100 m H <sub>2</sub> O	1.5 m H <sub>2</sub> O
- accuracy**	0.5 cm H <sub>2</sub> O	1 cm H <sub>2</sub> O	2.5 cm H <sub>2</sub> O	5 cm H <sub>2</sub> O	0.5 m H <sub>2</sub> O
- resolution	0.2 cm H <sub>2</sub> O	0.4 cm H <sub>2</sub> O	1 cm H <sub>2</sub> O	2 cm H <sub>2</sub> O	0.1 cm H <sub>2</sub> O

\* various measuring methods available (fixed, event based, averaging and pumping tests)

\*\* within temperature compensated range

# CTD-Diver datalogger



## Applications

- Aquifer recharge projects
- Saltwater intrusion projects
- Surveillance against (illegal) discharges
- Surveillance on waste disposal sites
- Monitoring groundwater or surface water quality

## CTD-Diver: reliable in all conditions

Where there is a need to monitor not only groundwater levels but also salinization, salt-water intrusion or contamination in the case of (illegal) discharges and landfill sites, the CTD-Diver is the instrument of choice. Besides a pressure and temperature sensor, the CTD-Diver has a four-electrode conductivity sensor for determining conductivity across a substantial measurement range (0-80 mS/cm). For each measurement, the date and time, groundwater level, temperature and conductivity are recorded. There are two options for conductivity measurement: display the measured conductivity or a specific conductivity at 25 °C. The CTD-Diver is accommodated in a ceramic casing which is resistant to corrosive conditions. The CTD-Diver has a memory with a maximum storage capacity of 16,000 measurement data per parameter.

## Specifications:

Dimensions	Ø22 mm x 183 mm
Memory	16,000 measurements (non-volatile)
Sample rate *	0.5 sec to 99 hours
Housing material	ceramic (ZrO <sub>2</sub> )
Temperature range	-20 °C to 80 °C
- accuracy	±0.1 °C
- resolution	0.01 °C
Conductivity:	
- range	0 to 80 mS/cm
- accuracy	±1% of reading
- resolution	0.1% of reading
Battery life	10 years (depending on use)
Weight	150 grams



## Highlights:

- 3 year warranty
- Long-term and frequent measurements
- Various measurement methods:
  - fixed
  - event dependent
  - pumping tests
- Simple calibration
- Temperature corrected measurement
- Reliable and accurate measurement data
- Compact size
- Robust construction:
  - ceramic
  - corrosion resistant
- Measures three parameters:
  - conductivity
  - temperature
  - pressure



## CTD-Diver® Technical specifications (pressure)

Type	DI 261	DI 263	DI 265	DI 500 (Baro)
Range	10 m H <sub>2</sub> O	30 m H <sub>2</sub> O	100 m H <sub>2</sub> O	1.5 m H <sub>2</sub> O
- accuracy**	1 cm H <sub>2</sub> O	3 cm H <sub>2</sub> O	10 cm H <sub>2</sub> O	0.5 m H <sub>2</sub> O
- resolution	0.2 cm H <sub>2</sub> O	0.6 cm H <sub>2</sub> O	2 cm H <sub>2</sub> O	0.1 cm H <sub>2</sub> O

\* various measuring methods available (fixed, event based and pumping tests)

\*\* within temperature compensated range (0°C to 40°C)

# Accessories



## Reading Unit

When the Diver is installed in the monitoring well by means of steel wire, the measured data can be readout on a PC, laptop or PocketPC with a Reading Unit equipped with a USB output. The dedicated software can also be used to program the Diver in the field or in the office. For reading and/or programming purposes, the mounting cap is removed from the Diver and the datalogger is placed in the Reading Unit. Subsequently the stored data can be readout and if necessary the Diver can be re-programmed.

## Diver Data Cable

For optimized usability the Diver Data Cable (DDC) can be used. This makes it possible to read or program the Diver at the top of the monitoring well without withdrawing the instrument. The DDC is compatible with all Diver models and is available in several lengths up to 300 metres. In order to readout the Diver, a PC, laptop or PocketPC is connected to the DDC by an interface cable. The stored data can then be readout and if necessary the Diver can be re-programmed.

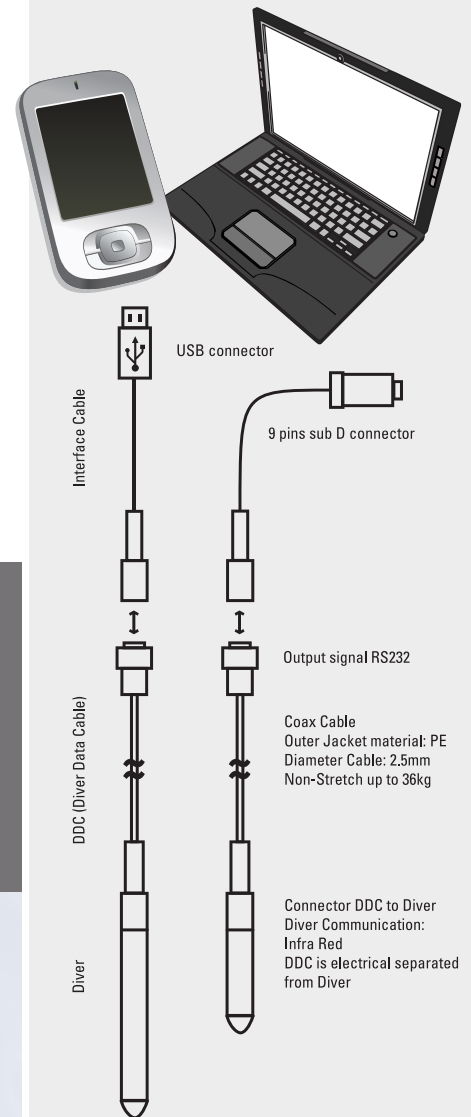



# Software

## LoggerDataManager

To manage all your Diver data

The Logger Data Manager software package simplifies readout and programming of the Diver. These tasks can be done through a Reading Unit or directly through the Diver Data Cable and interface cable connected to a PC, laptop or PocketPC.

### Programming

- Measuring site
- Instrument code
- Measurement method and frequency
- Direct or future start

### Readout

- Groundwater level
- Groundwater temperature
- Electrical conductivity (CTD-Diver)
- Times of measurements

### Data management and processing

- Smart Future Start
- Programming Divers, measuring sites and series
- Storing measurement data (name, code, height, assigned BaroDiver)
- Connecting multiple measuring sites to a given BaroDiver location
- CTD Calibration Wizard
- Barometric Compensation Wizard
- Manual measurement
- Graphical or tabular display or printout
- Export function for further processing
- Various export formats (e.g. CSV, MON, NITG)

Program & Readout

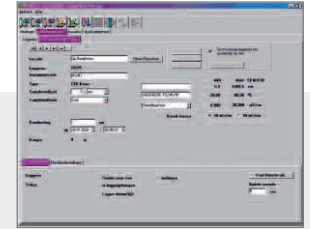
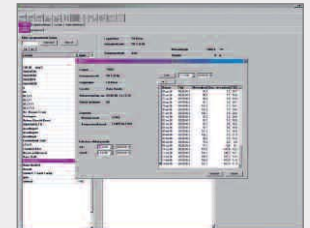
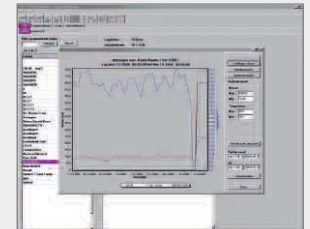

Table Visualization of Data



Graphical Visualization of Data



## Pocket-Diver

Simple software solution for on the field

Pocket-Diver is a software package that can be used on a PocketPC for programming Divers and reading stored measurements. Pocket-Diver comes in two variants: the 'Pocket-Diver Reader' enables you to read data, while 'Pocket-Diver Manager' also includes the Diver programming facility. For this purpose, the Divers must be connected to a Reading Unit or through an interface cable to the Diver Data Cable.

### Programming

- Measuring site
- Instrument code
- Measurement frequency and method
- Direct or future start

### Readout

- Groundwater level
- Groundwater temperature
- Electrical conductivity (CTD-Diver)
- Times of measurements

### Data management and processing

- Smart Future Start
- Barometric Compensation Wizard
- CTD-Diver Calibration Wizard
- All measured parameters of a series in a single graph
- Various export formats (CSV and MON)
- Software co-supplied
- Manual measurement

Program & Readout

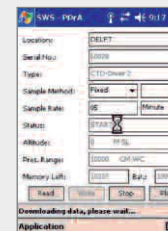

Graphical Visualization

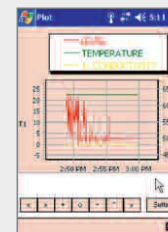

Adjusting Projects

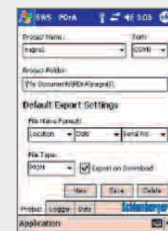





# Software

## HydroGeo Analyst

### An All-in-One Groundwater & Borehole Data Management & Visualization Solution

The most advanced environmental database solution available in the market today. HydroGeo Analyst offers the first truly all-in-one solution. It integrates a complete range of easy-to-use analysis and reporting tools, with a powerful yet extremely flexible database technology in an innovative GUI (graphical user interface). Meet your project demands with the highest level of performance and scalability!

#### Flexible database structure

- Handle virtually any database structure.
- Seamlessly translate your data to the GUI.
- Import both your database structure, and datum, fast and efficiently.

#### Scaleable databases

- Expand the scope, size, and structure of your
- Add or remove tables and fields, design unlimited numbers of lookup tables or soil specifications, and even export the modified database structure to new projects.

#### Applications

- HydroGeo Analyst is ideal for a wide range of specializations requiring data collection, management, visualization, and reporting.
- Control data for municipal, state, and national groundwater monitoring networks.
  - Administer data associated with remediation projects.
  - Interpret geologic and hydrostratigraphic data.
  - Map and report GIS aquifer extents and geologic formations.
  - Store sanitary landfill monitoring data.
  - Report downhole data (borehole lithology, geophysics, concentrations, etc.).

#### Mapping & Contouring Diver Data

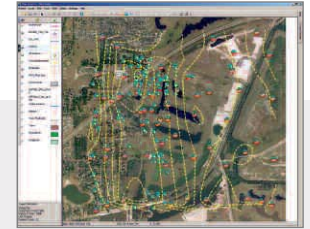

#### Logging & Reporting of Borehole Data

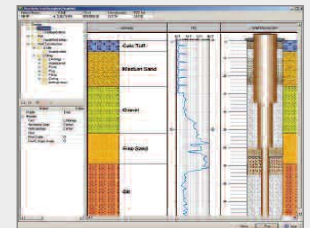

#### 3D Visualization of Monitoring Network

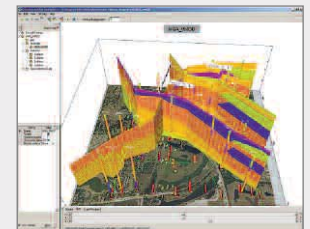

## AquiferTest Pro

### Pumping Test & Slug Test Data Analysis

Quick and easy-to-use, specifically designed for graphical analysis and reporting of pumping test and slug test data. AquiferTest Pro offers all the features and tools you need to calculate your aquifer's hydraulic properties, in one program.

#### Features

- Enhanced GUI design: Fresh GUI design consolidates features and offers improved analysis capabilities.
- Flexible data import: Import data from Diver Datalogger, Excel, ASCII, TXT or virtually any other data logger on the market.
- Advanced derivative analyses: Graphically display drawdown or type curve derivatives for improved assessment of pump test data.

- Revolutionary analysis methodology: Assess a multitude of aquifer conditions as an alternative to type curve matching.
- Trends correction: Compensate for barometric pressure effects or trends in water levels.

#### Applications

- Develop hydraulic conductivity values to use as input to 3D groundwater flow models.
- Predict drawdown effects resulting from groundwater pumping.
- Optimize pumping test design, considering well diameter, pumping rate, screened interval, etc.
- Optimize the placement of withdrawal wells due to proximity to existing wells.
- Determine the presence of flow boundaries or well interference during water pumping.
- Prepare professional pumping test reports to submit to water authorities.
- Map and contour drawdown data from groundwater pumping.

#### Import Diver Water Levels

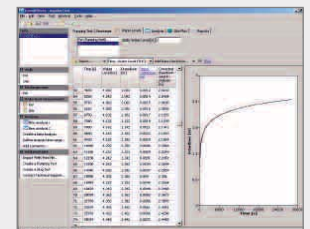

#### Import BaroDiver Trends

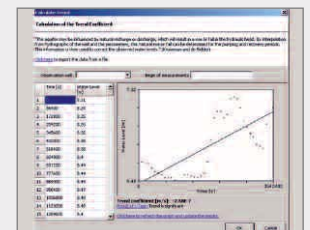

#### Contour & Report Pumping Test Drawdown

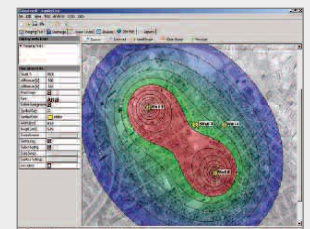

**We are the first China-based professional water and environmental consultants. We provide a total solution to every groundwater issue.**



Beijing Water International Ltd.  
KeQun Plaza East 411  
30 Xue Yuan Road  
Beijing, CHINA 100083  
Tel: (+86) 10 8233 6364  
info@beijingwaterltd.com

<http://www.beijingwaterltd.com>

